

DTS238-7-R three phase din rail type watt hour meter (D3706)



The meter is used in three phase four wire/three phase three wire/two phase three wire power grid. The meter is designed to measure AC active energy. All of its functions comply with the relative technical requirement for class 1 three phase watt hour meter in IEC62053-21. It is a long life meter with the advantage of high stability, high over load capability, low power loss and small volume.

Basic Function

- ★Mechanical step register 5+1 or 6
- ★Bi-directional total active energy measurement, reverse active energy measure in the total active energy
- ★Pulse LED indicates working of meter, Pulse output with optical coupling isolation
- ★Loss phase LED indication
- ★35mm din rail installation, bottom type wire connection

Technical Data

Rate voltage	DTS238-7-R three phase four wire 3x127/220V, 3x120/208V, 3x220/380V, 3x230/400V, 3x240/415V
Working voltage range	0.8~1.2Un
Rate Current	5A/CT, 1.5(6)A, 5(60)A, 10(100)A, or other as required
Frequency	50Hz or 60Hz
Connection mode	CT type or Direct type
Display	mechanical step register
Accuracy class	1.0
Power consumption	<2W/10VA
Start current	0.004Ib

Noting : other voltage , current are also available . Other function also can be special design as customer requirement

DTS238-7-R three phase din rail type watt hour meter (D3706)

AC voltage withstand	4000V/25mA for 60 sec
Impulse Voltage	6kV 1.2μs waveform
IP grade	IP51
Constant	800~3200 imp/kWh
Pulse output	Passive pulse, pulse width is 80 ± 5 ms
Executive standard	DIN 43880, IEC62053-21, IEC62052-11
Work temperature	-30°C~70°C
Outline dimension LXMxH	122x100x65mm(long terminal cover) 122x115x65mm(long terminal cover)
Weight	Approx 0.68kg

Environment

Operating temperature	-25°C~55°C
Storage temperature	-40°C~80°C
Reference temperature	23°C ± 2°C
Relative humidity	0 to 95%, non-condensing
Altitude	Up to 2500m
Warm up time	10s
Mechanical Environment	M1
Electromagnetic Environment	E2
Degree of pollution	2

Wire connection

(1) three phase four wire direct connection

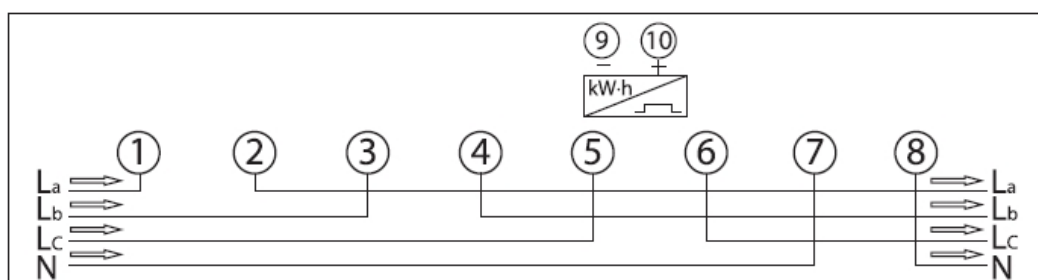

(2) three phase four wire through current transformer connection

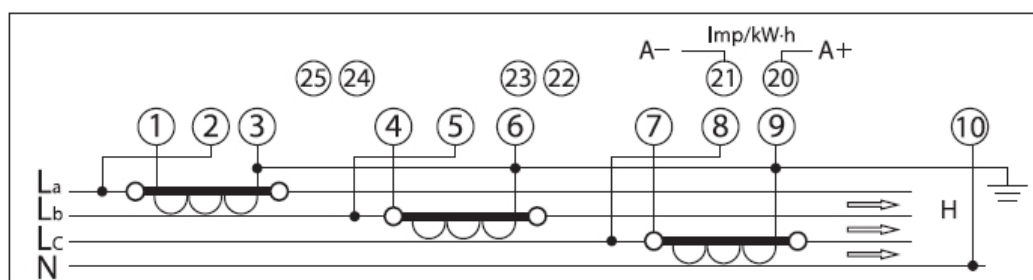

Noting : other voltage , current are also available . Other function also can be special design as customer requirement

DTS238-7-R three phase din rail type watt hour meter (D3706)

Outline dimension

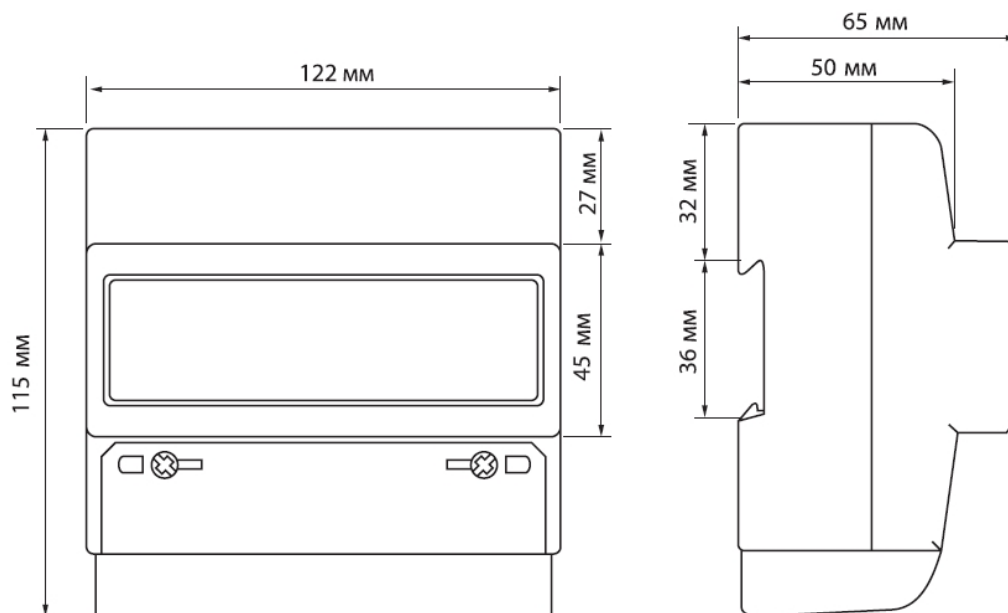

Noting : other voltage , current are also available . Other function also can be special design as customer requirement